

**WARNING**

1. Turn power off before inspection, installation or removal.
2. The installation should be performed by qualified electricians or lighting technicians.
3. Before conducting any installation, maintenance, or removal, disable all power to the luminaires and wait until the fixture cool down.
4. Do not touch the fixture while it is in service.
5. If there is any problem with the fixture, DO turn off power and DO NOT attempt repair unless you are a qualified technician or the customer service member.

## Installation Guide

### A. Surface mounting

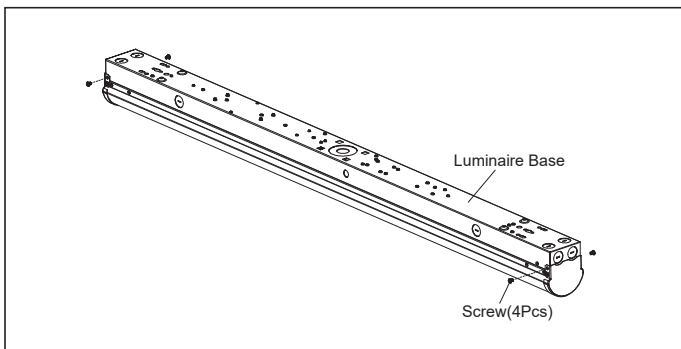

1. Unscrew the 4pcs screws on the back box of the luminaire or the luminaire base.

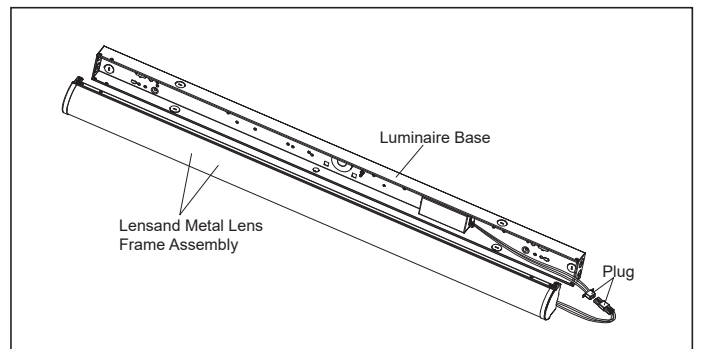

2. Disconnect the wire plug to start installation.

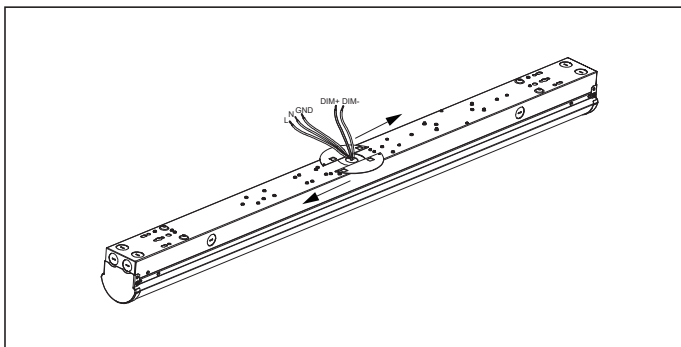

3. Install and lock the mounting plate on the luminaire base following the arrow.

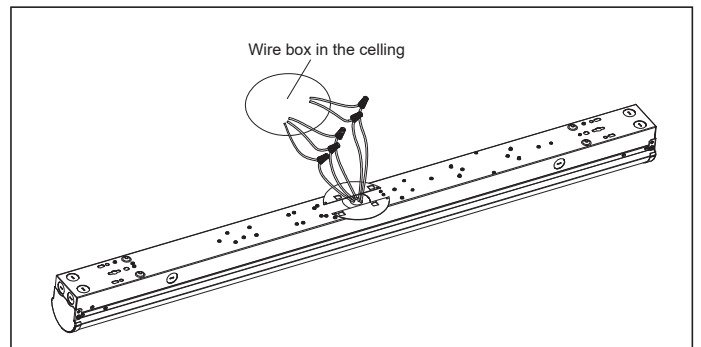

4. Connect the AC wires and dimming wires.

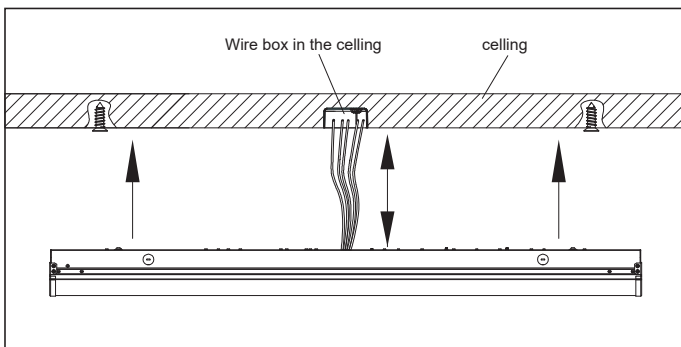

5. After wire connection complete, Fix the screws on the ceiling.

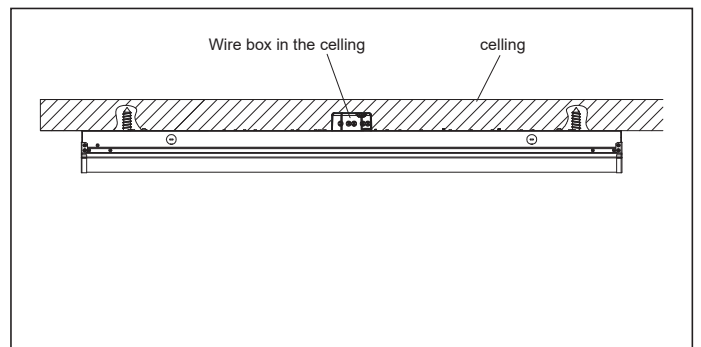

6. Align the holes of the fixture with the screws on the ceiling and slide it to the side to lock the fixture.

## B. Chain mounting

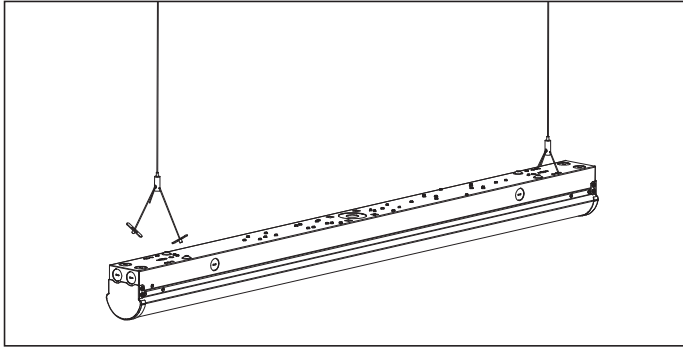

1. Clip the aircraft cable into the planned holes.

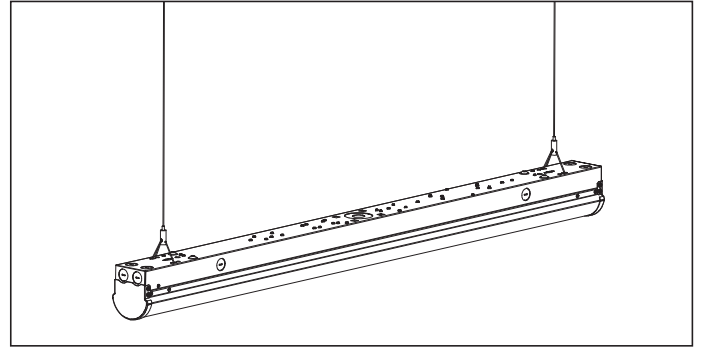

2. Adjust the cables to achieve balance.

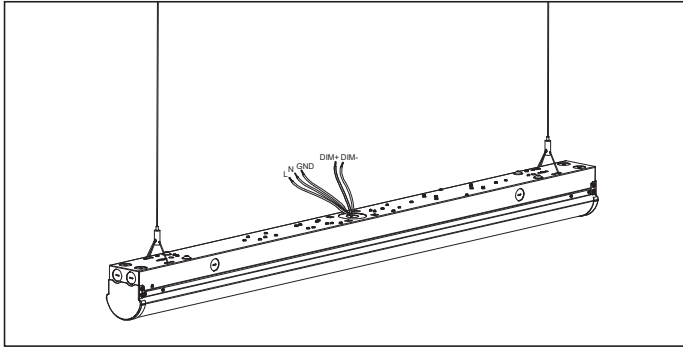

3. Connect the AC wires and dimming wires.

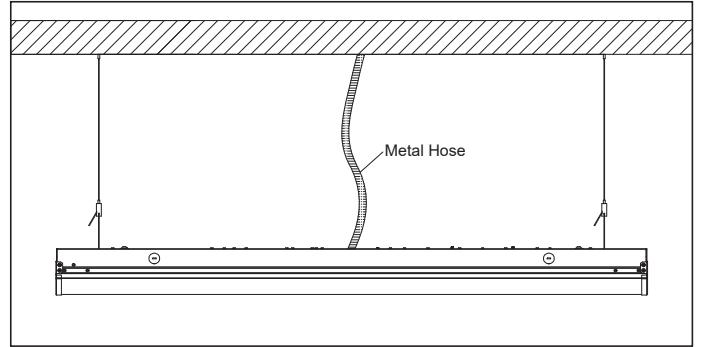

4. Wrap the wires with metal conduit.

## C. T-Bar clip mounting

Fix fixture to T-bar ceiling grid with T-bar clips which provided by customer. Refer to the left drawing, fix T-bar clips on Position " C " .

## Mounting hole indicator

- A. Keyhole Slots for Surface Mounting.
- B. V-Hook Openings for Chain Hanging.
- C. T-Bar Clip Mounting Hole.

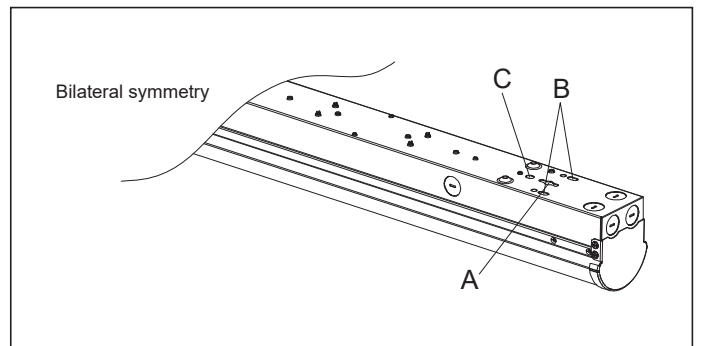

## WIRING

Universal voltage driver permits operation at 120V thru 277V, 60 Hz.  
For 0-10V Dimming, follow the wiring directions as in fig.1

1. Connect the black fixture lead to the (+) LINE supply lead.
2. Connect the white fixture lead to the (-) COMMON supplylead.
3. Connect the GROUND wire from fixture to supply ground. Do NOT connect the GROUND of the dimming fixture to the output.
4. Connect the purple fixture lead to the (V+) DIM lead.
5. Connect the gray fixture lead to the (V-) DIM lead.

## TROUBLESHOOTING

1. Check that the line voltage at the fixture is correct.  
Refer to wiring directions.
2. Is the fixture grounded properly?
3. Be sure the photocell, if used, is functioning properly.

## CLEANING & MAINTENANCE

**CAUTION: Be sure fixture temperature is cool enough to touch. Do not clean or maintain while fixture is energized.**

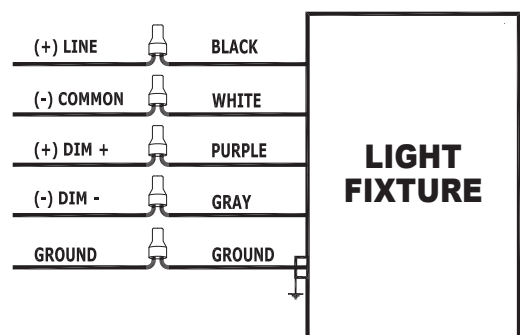

Fig. 1