

⚠ WARNING

PLEASE READ ALL INSTRUCTIONS BEFORE ATTEMPTING INSTALLATION

- To prevent personal injury or product damage only licensed electricians should install.
- To avoid electric shock or component damage, disconnect power before attempting installation or servicing.
- This product must be installed in accordance with the national electric code (NEC) and all applicable federal, state, and local electric codes and safety standards.
- Disconnect product and allow cooling prior to servicing.
- Any alteration or modification of this product is expressly forbidden as it may cause serious personal injury, death, property damage, and/or product malfunction.
- To prevent product malfunction an/or electrical shock this product must be properly grounded.
- This luminaire is designed to operate in ambient temperatures ranging from -40°F to 104 °F and to be horizontally mounted with the LEDs facing down.
- This product must be installed in accordance with the applicable installation code by a person familiar with the construction and operation of the product and the hazards involved.
- MIN 167°F (75°C) SUPPLY CONDUCTORS
- CONSULT A QUALIFIED ELECTRICIAN TO ENSURE CORRECT BRANCH CIRCUIT CONDUCTOR
- CAUTION - RISK OF FIRE
- When equipped with a Photocell, Adjustable Pole/Slipfitter/Yoke mount tilt angle should not exceed 15°.
- This product is not suitable for several special environments, such as places with corrosive gas liquids or high pressure water vapor.

Content

Mount Installation Guide	P1
Mounting Accessories	P3
Twist-Lock Photocell	P4
Multi-Level Motion Sensor (100W 120-277V)	P5
Multi-Level Motion Sensor (All Configurations Except 100W 120-277V)	P7
Motion Sensor Dip Switch Settings	P9

Mount Installation Guide

Square/Round Pole (Figure 1)

1. Loosen the four PM4*12mm screws and remove the side plate and rubber gasket from the mounting bracket. Please skip to Step 3 if using a Square Pole Mount.
2. If using the Round Pole Adaptor, place the adaptor between the arm and the pole, with the radius side of adaptor towards pole.
3. Pass the two 1/2"*1.97" hex bolts from inside of the pole through Round Pole Adaptor (if using it) and the back of the arm, slide on flat washers followed by M14 spring washers, tighten 1/2" nuts.
4. Feed the lead from the arm into the pole and make wiring connections inside the pole as per the wiring diagram on the next page.
5. Feed the fixture cord into the arm. Align threaded mounting holes of fixture with exposed ends of the two 5/16"*1.02" hexagon socket bolts, slide the fixture into the groove of the arm, and tighten the bolts to 15 N/m.
6. Inside the arm, make wiring connections between the lead from the fixture and lead from the arm as per the wiring diagram on the next page.
7. Reinstall the side plate and rubber gasket, tightening the screws. The gasket should be sitting flush between the side plate and mount, creating a tight seal around the edges.

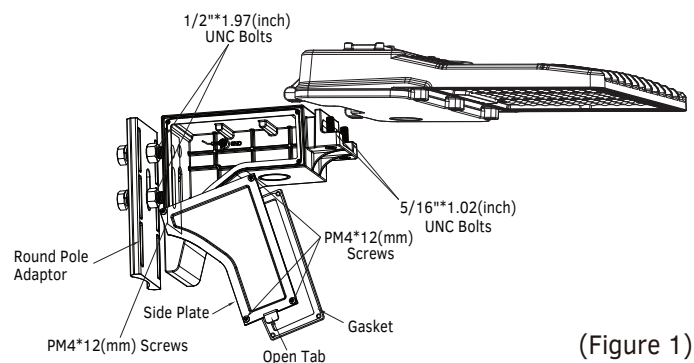

(Figure 1)

Square Pole Mount Torque Values At Install for 1.5G Testing

100W	29.5 N/m
150W / 180W	29.2 N/m
250W / 300W	28.9 N/m

Adjustable Pole Mount (Figure 2)

1. Loosen the six PM4*12 screws and remove the two side plates.
2. Attach the bracket to the pole using the provided two 3/8" screws.
3. Loosen the M10 screw and adjust the fixture to the desired angle.
3. Route the cord into the mounting bracket through the wiring hole, slide the fixture onto the bracket and tighten the two bottom 5/16" screws.
4. Make wiring connections as per the wiring diagram on the next page, replace the two side plates, and fasten the PM4*12(mm) screws. When replacing the side plates, make sure that the power cord is not exposed and does not press against the wiring.

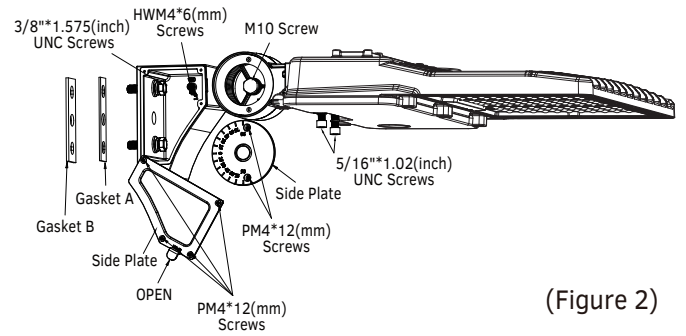

(Figure 2)

Wall Mount (Figure 3)

1. Loosen the four PM4*8(mm) screws and remove the side plate from the mounting bracket.
2. Attach the back plate to the arm bracket using the KM4*10(mm) screws.
3. Use the provided plastic template to locate the places to drill the holes in the wall, then attach the bracket to the wall using four 3/8" screws (not included).
4. Route the power cord into the mounting bracket, slide the fixture onto the bracket, then tighten the two bottom 5/16"*1.02" bolts to 15 N/m.
5. Make wiring connections as per the wiring diagram on the next page, replace the side plate, and fasten the PM4*8(mm) screws.

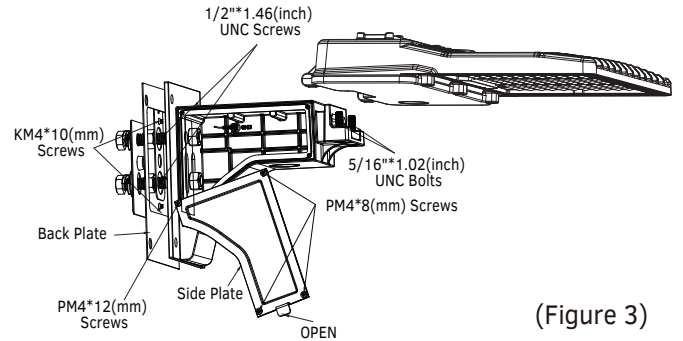

(Figure 3)

Slipfitter (Figure 4)

1. Loosen the two PM4*12(mm) screws and remove the side plate from the mounting bracket.
2. Route the cord into the mounting bracket through the wiring hole, slide the fixture onto the bracket and tighten the two bottom 5/16"*1.02" bolts to 15 N/m.
3. Loosen the HM10*25mm hex bolt to adjust the bracket to the desired angle. Once the fixture is at the desired angle, retighten the HM10*25mm hex bolt.
4. Make wiring connections per the wiring diagram below.
5. Slip lower fitter over 2 - 3/8" (60 mm) o.d. heavy wall pipe or tenon and tighten the four M8*20mm hexagon head set screws, making sure not to pinch any leads.

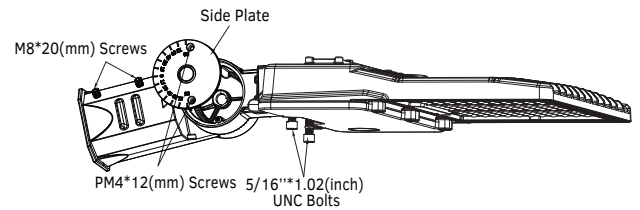

(Figure 4)

Slipfitter Mount Torque Values At Install for 1.5G Testing

100W	27.9 N/m
150W / 180W	27.9 N/m
250W / 300W	28.3 N/m

Yoke Mount (Figure 5)

1. Route the cord into the mounting bracket through the wiring hole, slide the fixture onto the bracket and tighten the two 5/16"*1.02" bolts to 15 N/m.
2. Use the hole pattern on the yoke mount to locate the places to drill the holes in the installation surface, then attach the mount to the surface using using 3/8"*1-1/2" hex screws (not included).
3. Loosen the center bolts and set screws, rotate the fixture to the desired angle, then tighten the center bolts.
4. Make wiring connections per the wiring diagram below.
5. After setting the mount to the desired angle, the center bolts and set screws should be locked using a manual wrench.

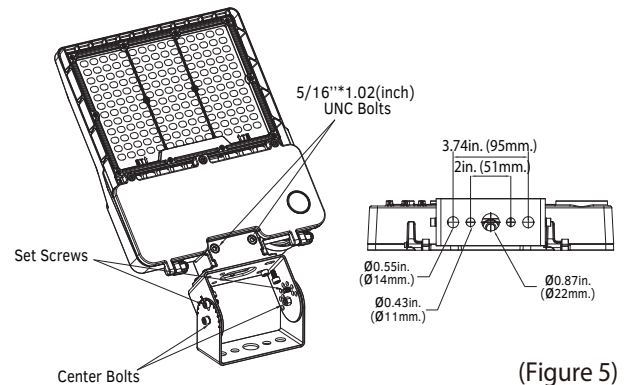

(Figure 5)

Backlight Glare Shield (Figure 6) - Optional

1. Position the glare shield facing forward, so that the holes on the sides of the glare shield align with the pre-drilled holes on the sides of the fixture.
2. Use the provided PM4*6(mm) screws to securely attach the glare shield to the fixture.

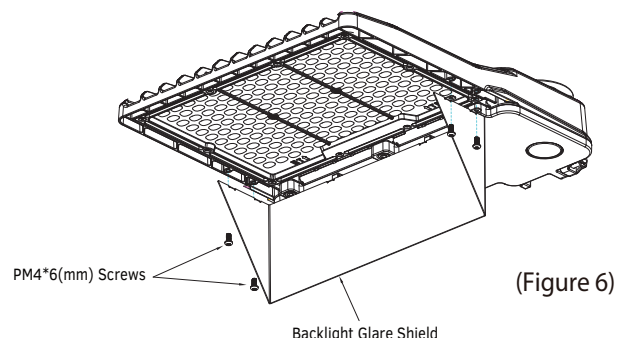

(Figure 6)

Wiring Diagram

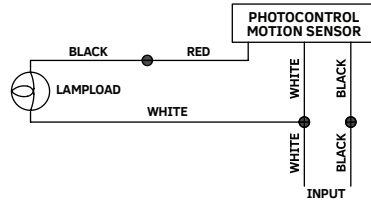
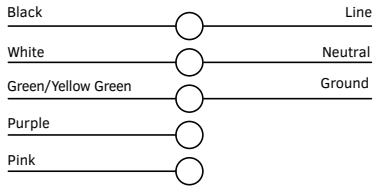

- Note:** 1. Two dimming wires in the the driver box.
2. A black/white 12V+ wire may be present and unconnected in some fixtures.

Mounting Accessories

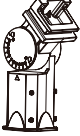
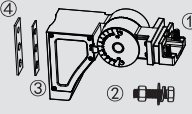
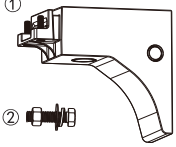
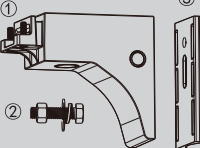
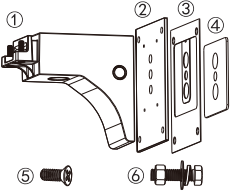
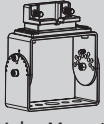
Mounting Type	Accessory	Specifications	Quantity
 Slipfitter Mount	Slipfitter Mount	Adjustable Slipfitter	1
 Adjustable Pole Mount	① Adjustable Pole Mount	235 x 90 x 152mm Adjustable Pole Mount	1
	② Bolt	#3/8"*1.575" Stainless Steel Hexagon Head Bolt	2
	③ Gasket A	L100W22H2 Gasket	1
	④ Gasket B	L100W30H3 Gasket	1
 Square Pole Mount	① Pole Mount Arm	202 x 177 x 90mm Square Pole Mount Arm	1
	② Bolt	#1/2" x 1.97" Stainless Steel Hexagon Head Bolt	2
 Round Pole Mount	① Pole Mount Arm	202 x 177 x 90mm Square Pole Mount Arm	1
	② Bolt	#1/2" x 1.97" Stainless Steel Hexagon Head Bolt	2
	③ Adaptor	177 x 88 x 13mm Round Pole Adaptor	1
 Wall Mount	① Pole Mount Arm	202 x 177 x 90mm Square Pole Mount Arm	1
	② Wall Mount Plate	203 x 152 x 5mm Steel Plate	1
	③ Wall Mount Template	203 x 152 x 1mm Plastic Template	1
	④ EVA Gasket	L119W119H30 40° EVA Gasket	1
	⑤ Bolt	KM4 x 10" Stainless Steel Flat Head Bolt	4
	⑥ Bolt	#1/2" x 1.46" Stainless Steel Hexagon Head Bolt	2
 Yoke Mount	Yoke Bracket	L129.5W60H88 Upper Bracket + L138W60H88 Lower Bracket +L44.5W115H49 Bracket	1
Other	Twist-Lock Photocell	120-277V 3-Pin	1
	Receptacle	3-Pin Receptacle	1
	Bolt	PM4x8 Stainless Steel Round Flat Bottom Bolt	2
	Occupancy Sensor	120-277 0-10V Bi-Level	1

Optional - Twist-Lock Photocell

Please Note: If a Twist-Lock Photocell is installed, a Multi-Level Motion Sensor cannot be installed.

Photocell Dimensions & Specifications

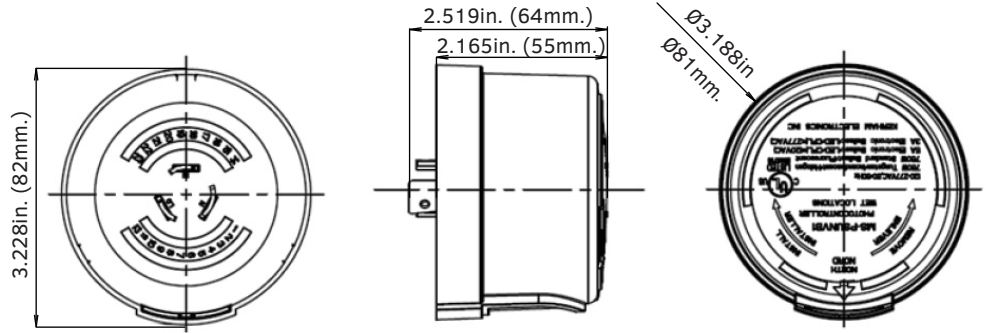

120-277V Specifications

Power Supply: 90-305VAC (Certified Input Range 100-277VAC) 50/60Hz
Power Consumption: .7W
Illumination Threshold: On at 10-20 Lux, off at 60-80 Lux
Humidity: Max. 99% RH
Operating Temperature: -40°F to 176°F (-40°C to 80°C)
Net Weight: 90g±2g

480V Specifications

Power Supply: 347-530VAC (Certified Input Range 480VAC) 50/60Hz
Power Consumption: .5W
Illumination Threshold: On at 16 Lux, off at 24 Lux
Humidity: Max. 99% RH
Operating Temperature: -40°F to 158°F (-40°C to 70°C)
Net Weight: 110g

Photocell & Receptacle Installation (Figure 7)

1. Remove the three screws and open the cover of the power compartment.
2. Remove the four screws at the location of the photocell hole and take off the pressure plate.
3. Place the matching silicone gasket on the photocell receptacle, then use screws to secure the photocell receptacle to the photocell hole position.
4. Push the twist-lock photocell into the receptacle and twist it clockwise to lock it in place. It is recommended to install the photocell facing the NORTH direction as indicated on the top of the photocell. The receptacle position should be adjusted if necessary.
5. Complete the wiring for the photocell according to the wiring diagram, below and connect the wires.
6. Close the cover of the power compartment and tighten the screws, ensuring that all wires are not pinched.

Only Photocell Installation (With Preinstalled Receptacle)

1. **IMPORTANT:** Make sure power to the fixture is disconnected prior to photocell installation.
2. Push the twist-lock photocell into the receptacle and twist it clockwise to lock it in place. It is recommended to install the photocell facing the NORTH direction as indicated on the top of the photocell. The receptacle position should be adjusted if necessary.

Photocell Receptacle Wiring Diagram

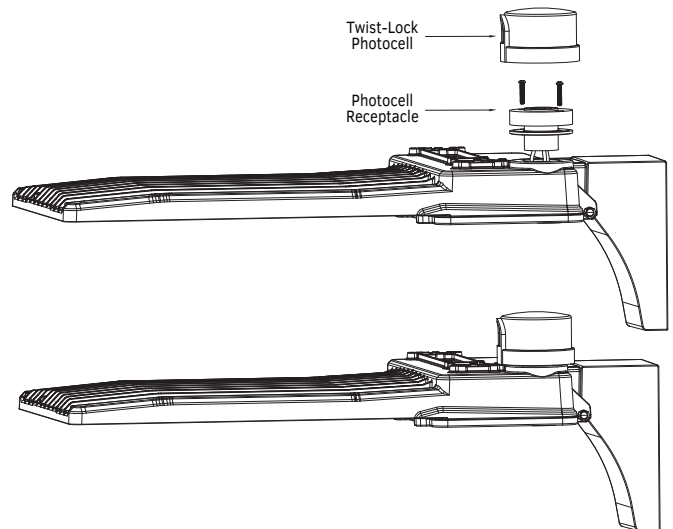
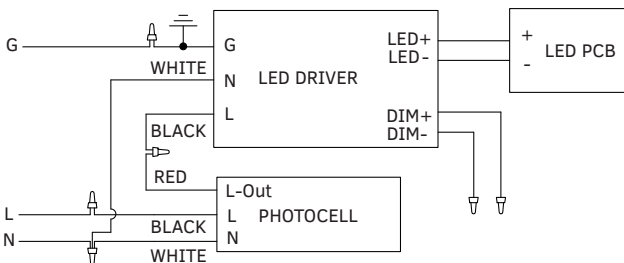

(Figure 7)

Optional - Multi-Level Motion Sensor (For 100W 120-277V & All 480V)

Please Note: If a Multi-Level Motion Sensor is installed, a Photocell cannot be installed.

Motion Sensor Dimensions & Specifications (For Sensor Factory Settings, See P. 9)

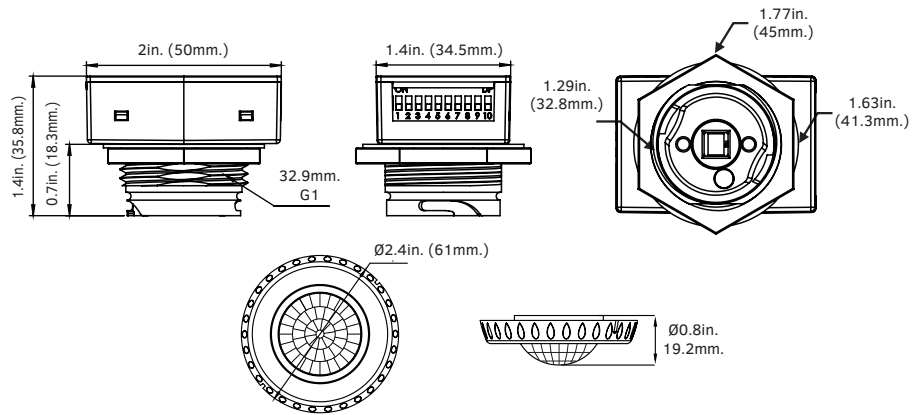
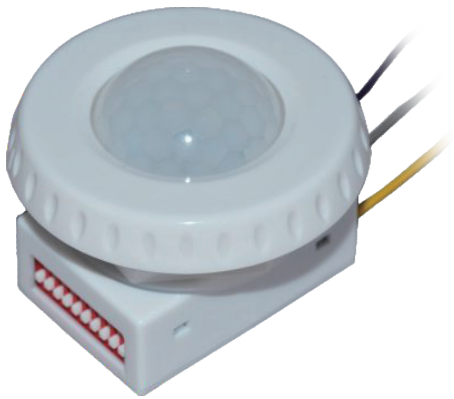

Specifications

- Power Supply:** 12-24V DC
- Dimming Control Output:** 0-10V, max. 25mA sinking current
- Detection Radius & Angle:** 30' @ 40' Mounting Height, 360°
- Mounting Height:** Max. 40'
- Humidity:** Max. 95% RH
- Operating Temperature:** -40°F to 167°F (-40°C to 75°C)

Sensor Coverage

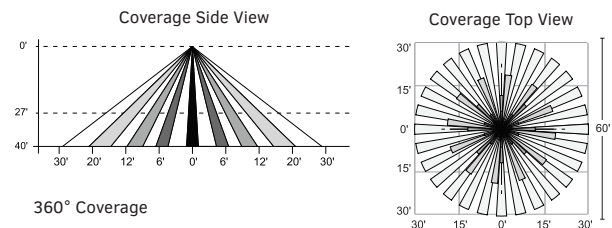

Sensor Indicator LED

- The sensor LED always lights up after power is switched on, and turns off after the unit enters the working state.
- The sensor LED will flash once when the unit receives a sensing signal.

Multi-Level Function

The motion sensor includes the capability for tri-level control functionality, for areas which require a preliminary notification consisting of a change in the brightness of the light before the light switches off completely. When the sensor is installed, there are 3 lighting modes: 100% --> dimmed (under reduced natural lighting conditions) --> off, with 2 periods of selectable waiting time: sensor hold time and sensor stand-by time. Additional configurable options include light threshold for sensor operation, and sensor sensitivity/detection area.

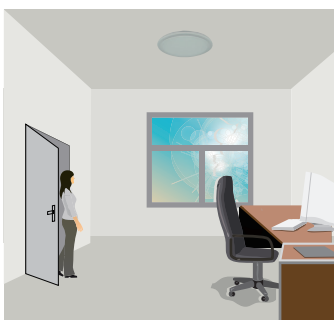

When natural lighting conditions are sufficient, the motion sensor does not turn on the fixture even when motion is detected.

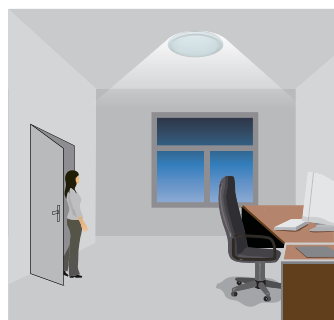

When natural lighting conditions fall below a selected threshold, the motion sensor turns on the fixture when motion is detected.

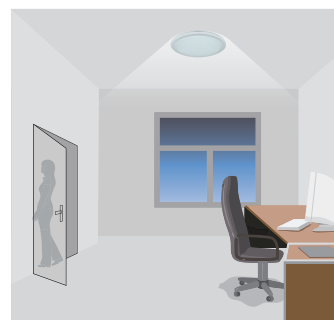

After sensor hold time elapses, the motion sensor dims the fixture to the stand-by light level if the natural light conditions are below the selected threshold.



After the stand-by time period elapses, the motion sensor switches the fixture off automatically.

NOTE: To eliminate the stand-by function, set the Stand-By Light Level to 0.

Daylight Sensor Function

Select the daylight sensor function by pushing  when the remote control is in setting mode.

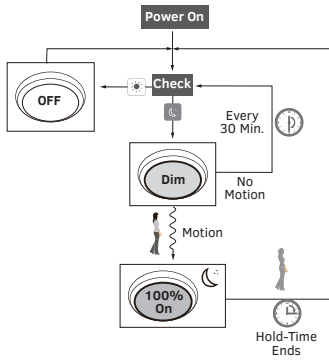

Settings In This Demonstration:

Hold-Time: 30 Minutes
 Setpoint On: 50 Lux
 Setpoint Off: 300 Lux
 Stand-By Dimming Level: 10%
 Stand-By Period: $+\infty$

(The $+\infty$ Stand-By Period option is only available when the Daylight Sensor is activated.)



When movement is detected, the light switches on to 100% brightness.

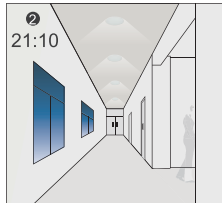

After sensor hold-time elapses, the light dims to the stand-by level.

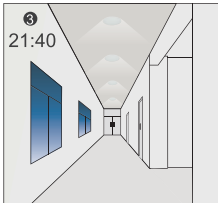

The light remains dimmed to the stand-by level at night.

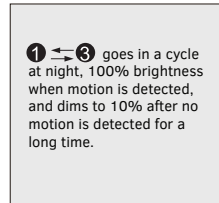

① → ③ goes in a cycle at night, 100% brightness when motion is detected, and dims to 10% after no motion is detected for a long time.

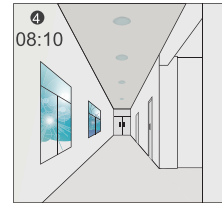

When the natural light level exceeds the "setpoint off" light level, the fixture will remain off even when the space is occupied.

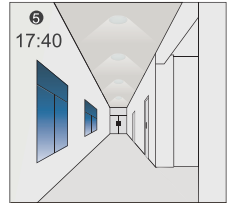

The light stays on at 10% brightness when motion is not detected and natural light conditions are insufficient.

Differences Between Multi-Level Function and Daylight Sensor Function

Multi-Level Function

- The daylight sensor acts as a threshold to assist motion sensor operation.
- The light is turned on when motion is detected and natural lighting conditions are insufficient.
- The light is turned off after the stand-by time period elapses.

Daylight Sensor Function

- The daylight sensor works independently of the motion sensor.
- The light is turned on when the natural light level exceeds the "Setpoint On" setting and motion is detected.
- The light is turned off when the natural light level falls below the "Setpoint Off" setting.

Motion Sensor Installation (Figure 8)

1. Remove the three screws and open the cover of the power compartment.
2. Use a screwdriver and hammer, or other suitable tools, to knock open the Sensor hole along the marked circle.
3. Place the Sensor onto the hole, fit it with a silicone gasket, tighten the nut, and then install the Sensor lens.
4. Follow the Sensor wiring diagram to connect the wires.
5. Close the cover of the power compartment and tighten the screws ensuring that all wires are not pinched.

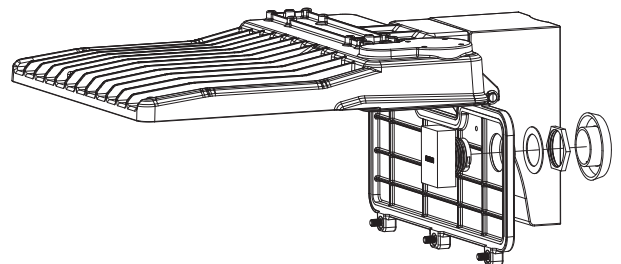
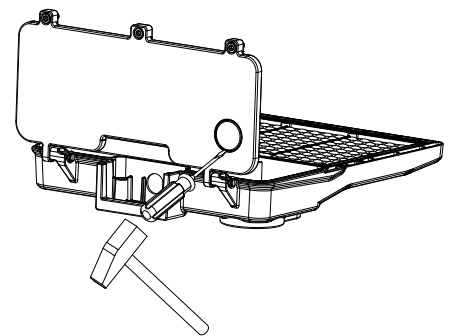

(Figure 8)

Motion Sensor Wiring Diagram 100W 120-277V & All 480V

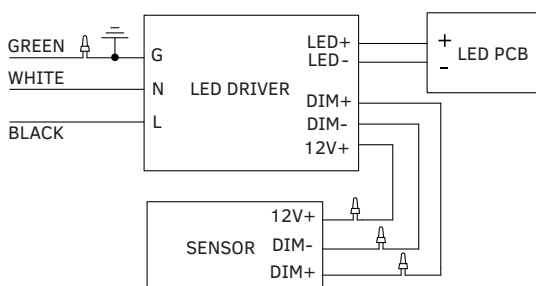

Optional - Multi-Level Motion Sensor (Except 100W 120-277V & All 480V)

Please Note: If a Multi-Level Motion Sensor is installed, a Photocell cannot be installed.

Motion Sensor Dimensions & Specifications (For Sensor Factory Settings, See P. 9)

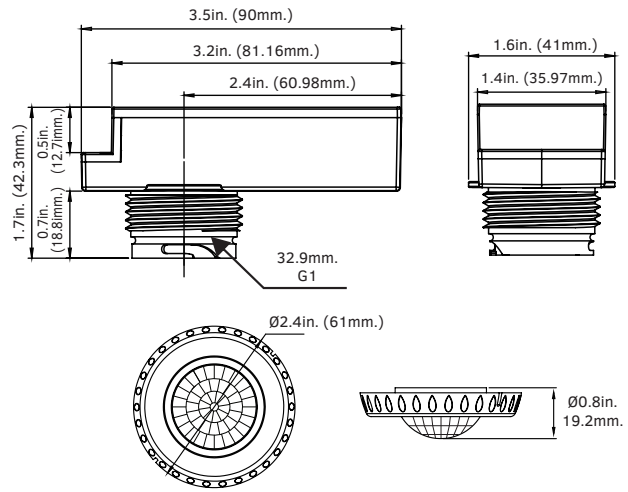

Specifications

- Power Supply:** 120/277VAC, 50/60Hz
- Dimming Control Output:** 0-10V, default 10V
- Detection Radius & Angle:** 30' @ 40' Mounting Height, 360°
- Mounting Height:** Max. 40'
- Humidity:** 20-90%
- Operating Temperature:** -40°F to 158°F (-40°C to 70°C)

Sensor Coverage

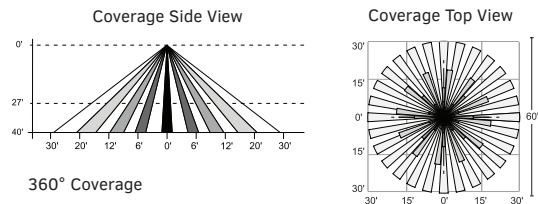

⚠ Important

- Sensor warm up time is 40 seconds. After the sensor connects to input power the first time, the light fixture will stay on for 40 seconds, then dim for normal operation.
- Factory Default Settings: Sensor Detection Range 100%, Sensor Hold Time 10 Seconds, Light Threshold 30 Lux, Stand-By Light Level 30%, Stand-By Time: 60 Minutes.
- When any setting is changed using the dip switches or remote control, the light fixture that the sensor is connected to will turn on and off to confirm the change.

Multi-Level Function

The motion sensor includes the capability for tri-level control functionality, for areas which require a preliminary notification consisting of a change in the brightness of the light before the light switches off completely. When the sensor is installed, there are 3 lighting modes: 100% --> dimmed (under reduced natural lighting conditions) --> off, with 2 periods of selectable waiting time: sensor hold time and sensor stand-by time. Additional configurable options include light threshold for sensor operation, and sensor sensitivity/detection area.

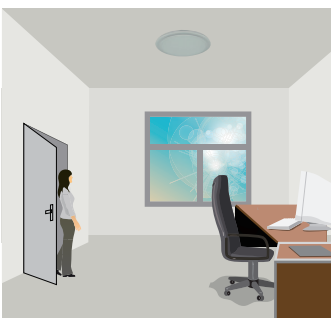

When natural lighting conditions are sufficient, the motion sensor does not turn on the fixture even when motion is detected.

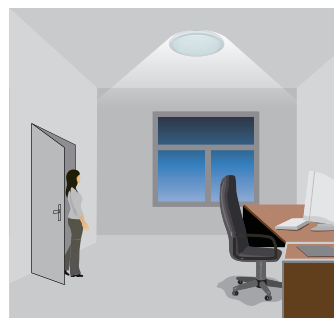

When natural lighting conditions fall below a selected threshold, the motion sensor turns on the fixture when motion is detected.

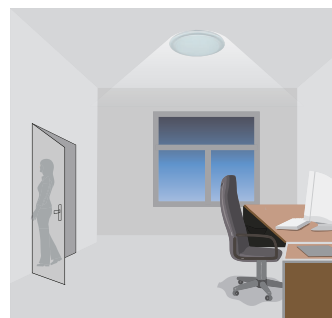

After sensor hold time elapses, the motion sensor dims the fixture to the stand-by light level if the natural light conditions are below the selected threshold.



After the stand-by time period elapses, the motion sensor switches the fixture off automatically.

Daylight Sensor Function

Select the daylight sensor function by pushing **(H)** when the remote control is in setting mode.

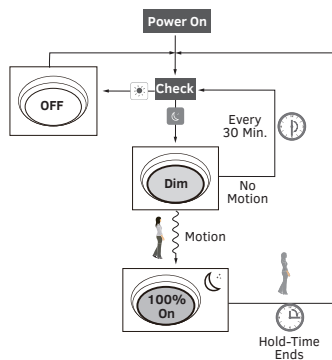

Settings In This Demonstration:

Hold-Time: 30 Minutes
 Setpoint On: 50 Lux
 Setpoint Off: 300 Lux
 Stand-By Dimming Level: 10%
 Stand-By Period: +∞

(The +∞ Stand-By Period option is only available when the Daylight Sensor is activated.)

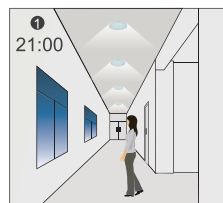

When movement is detected, the light switches on to 100% brightness.

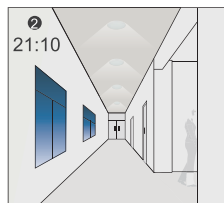

After sensor hold-time elapses, the light dims to the stand-by level.

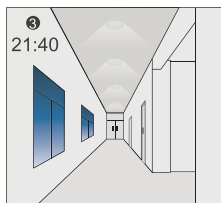

The light remains dimmed to the stand-by level at night.

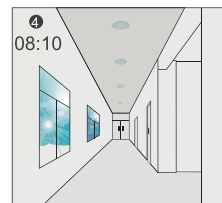
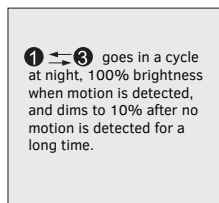

When the natural light level exceeds the "setpoint off" light level, the fixture will remain off even when the space is occupied.



The light stays on at 10% brightness when motion is not detected and natural light conditions are insufficient.

Motion Sensor Installation (Figure 9)

1. Remove the three screws and open the cover of the power compartment.
2. Use a screwdriver and hammer, or other suitable tools, to knock open the Sensor hole along the marked circle.
3. Place the Sensor onto the hole, fit it with a silicone gasket, tighten the nut, and then install the Sensor lens.
4. Follow the Sensor wiring diagram to connect the wires.
5. Close the cover of the power compartment and tighten the screws ensuring that all wires are not pinched.

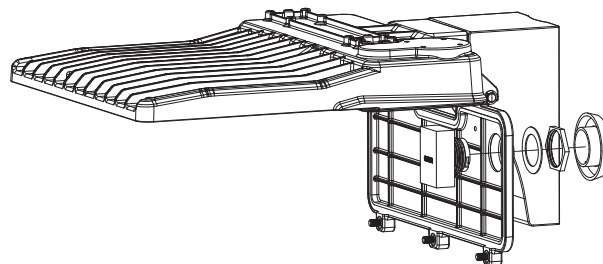
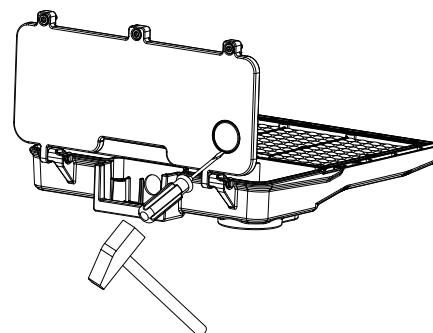

(Figure 9)

Motion Sensor Wiring Diagram Excluding 100W 120-277V & All 480V

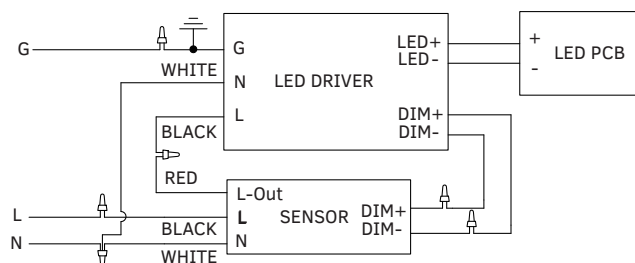

Motion Sensor Dip Switch Settings

For Both Multi-Level Motion Sensors

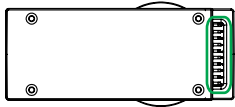
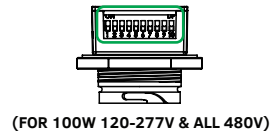

Dip Switch Factory Settings

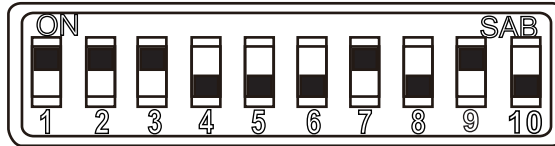

SENSOR DETECTION RANGE: 100% STAND-BY LIGHT LEVEL: 30%
 SENSOR HOLD TIME: 5 MINUTES STAND-BY TIME: 30 MINUTES
 LIGHT THRESHOLD: DISABLED

The operating parameters of the motion sensor may be adjusted directly from the sensor or remotely using an optional remote control. Adjustments made directly to the sensor are done using a set of dip switches on the sensor body, in the locations indicated in the above image.

Dip Switch Parameter Settings

Each motion sensor parameter may be adjusted by using a set of two adjacent dip switches. Dip switches 1 & 2 set sensor sensitivity, dip switches 3 & 4 set sensor hold time, dip switches 5 & 6 set the level of lux for sensor activation, dip switches 7 & 8 set sensor stand-by light level, and dip switches 9 & 10 set sensor stand-by time.

Dip Switch 1 & 2: Sensor Detection Range (Sensitivity) Settings

Sensor detection range, describes the radius of the circular detection zone on the ground below a sensor installed on a fixture (maximum ceiling height 40ft). To adjust sensor detection range, put the dip switches to either an ON position (↑) or an OFF position (↓) as indicated in the guide below.

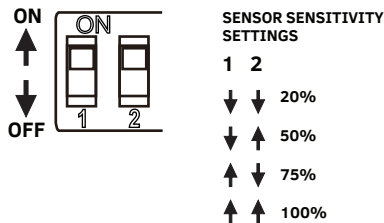

Dip Switch 3 & 4: Sensor Hold Time Settings

Upon detecting motion, the fixture light can be set to stay on for any period of time indicated in the options below. Any additional motion detected before the selected amount of time elapses will restart the timer. While adjusting the sensor detection zone and performing walk tests, it is recommended to select the shortest possible hold time. To adjust sensor hold time, put the dip switches to either an ON position (↑) or an OFF position (↓) as indicated in the guide below.

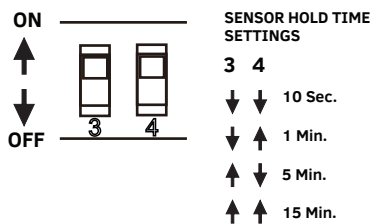

Dip Switch 5 & 6: Light Threshold Settings

The sensor light threshold indicates the ambient light level at which the sensor will begin to control the fixture. To adjust light threshold, put the dip switches to either an ON position (↑) or an OFF position (↓) as indicated in the guide below.

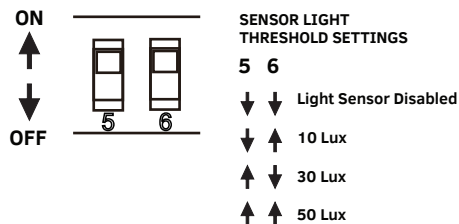

Dip Switch 7 & 8: Stand-By Light Level Settings

The stand-by light level determines the brightness of the fixture while the sensor is not detecting motion. To adjust stand-by light level, put the dip switches to either an ON position (↑) or an OFF position (↓) as indicated in the guide below.

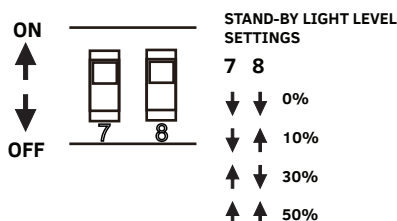

Dip Switch 9 & 10: Stand-By Time Settings

The stand-by time determines the length of time the fixture stays on while the sensor is not detecting motion. To adjust stand-by time, put the dip switches to either an ON position (↑) or an OFF position (↓) as indicated in the guide below.

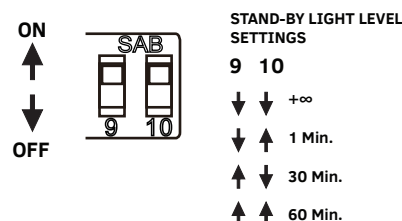

Instructions for Sensor Parameter Adjustment Using Remote Are Included with the Remote