

! WARNING

PLEASE READ ALL INSTRUCTIONS BEFORE ATTEMPTING INSTALLATION

- To prevent personal injury or product damage only licensed electricians should install.
- To avoid electric shock or component damage, disconnect power before attempting installation or servicing.
- This product must be installed in accordance with the national electric code (NEC) and all applicable federal, state, and local electric codes and safety standards.
- Disconnect product and allow cooling prior to servicing.
- Any alteration or modification of this product is expressly forbidden as it may cause serious personal injury, death, property damage, and/or product malfunction.
- To prevent product malfunction an/or electrical shock this product must be properly grounded.
- This luminaire is designed to operate in ambient temperatures ranging from -40°F to 113°F and to be horizontally mounted with the LEDs facing down.
- This product must be installed in accordance with the applicable installation code by a person familiar with the construction and operation of the product and the hazards involved.
- MIN 167°F (75°C) SUPPLY CONDUCTORS
- CONSULT A QUALIFIED ELECTRICIAN TO ENSURE CORRECT BRANCH CIRCUIT CONDUCTOR
- CAUTION - RISK OF FIRE
- When equipped with a Photocell, Adjustable Pole/Slipfitter/Yoke mount tilt angle should not exceed 15°.
- This product is not suitable for several special environments, such as places with corrosive gas liquids or high pressure water vapor.

Installation Guide

Square/Round Pole (Figure 1)

1. Loosen the four PM4*12mm screws and remove the side plate and rubber gasket from the mounting bracket. Please skip to Step 3 if using a Square Pole Mount.
2. If using the Round Pole Adaptor, place the adaptor between the arm and the pole, with the radius side of adaptor towards pole.
3. Pass the two 1/2"*1.97" hex bolts from inside of the pole through Round Pole Adaptor (if using it) and the back of the arm, slide on flat washers followed by M14 spring washers, tighten 1/2" nuts.
4. Feed the lead from the arm into the pole and make wiring connections inside the pole as per the wiring diagram on the next page.
5. Feed the fixture cord into the arm. Align threaded mounting holes of fixture with exposed ends of the two 5/16"*1.02" hexagon socket bolts, slide the fixture into the groove of the arm, and tighten the bolts to 15 N/m.
6. Inside the arm, make wiring connections between the lead from the fixture and lead from the arm as per the wiring diagram on the next page.
7. Reinstall the side plate and rubber gasket, tightening the screws. The gasket should be sitting flush between the side plate and mount, creating a tight seal around the edges.

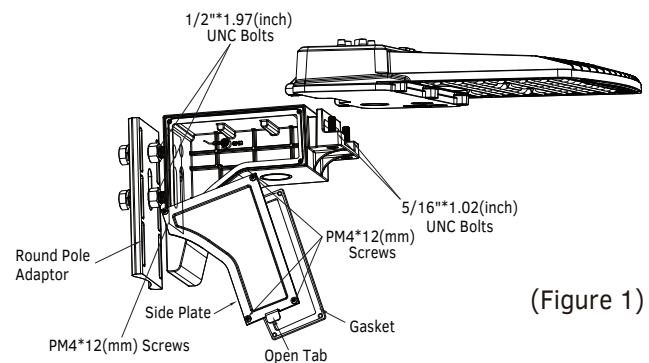

(Figure 1)

Wall Mount (Figure 2)

1. Loosen the four PM4*8(mm) screws and remove the side plate from the mounting bracket.
2. Attach the back plate to the arm bracket using the KM4*10(mm) screws.
3. Use the provided plastic template to locate the places to drill the holes in the wall, then attach the bracket to the wall using four 3/8" screws (not included).
4. Route the power cord into the mounting bracket, slide the fixture onto the bracket, then tighten the two bottom 5/16" screws.
5. Make wiring connections as per the wiring diagram on the next page, replace the side plate, and fasten the PM4*8(mm) screws.

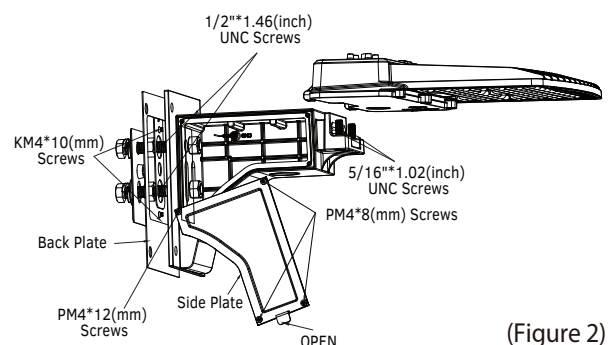

(Figure 2)

Slipfitter (Figure 3)

1. Loosen the two PM4*12(mm) screws and remove the side plate from the mounting bracket.
2. Route the cord into the mounting bracket through the wiring hole, slide the fixture onto the bracket and tighten the two bottom 5/16" screws.
3. Loosen the HM10*25mm hex bolt to adjust the bracket to the desired angle. Once the fixture is at the desired angle, retighten the HM10*25mm hex bolt.
4. Make wiring connections per the wiring diagram below.
5. Slip lower fitter over 2 - 3/8" (60 mm) o.d. heavy wall pipe or tenon and tighten the four M8*20mm hexagon head set screws, making sure not to pinch any leads.

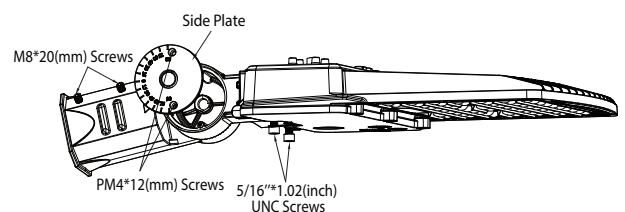

(Figure 3)

Yoke Mount (Figure 4)

1. Route the cord into the mounting bracket through the wiring hole, slide the fixture onto the bracket and tighten the two 5/16" screws.
3. Use the hole pattern on the yoke mount to locate the places to drill the holes in the installation surface, then attach the mount to the surface using 3/8" x 1-1/2" hex screws (not included).
3. Loosen the center bolts and set screws, rotate the fixture to the desired angle, then tighten the center bolts.
4. Make wiring connections per the wiring diagram below.
5. After setting the mount to the desired angle, the center bolts and set screws should be locked using a manual wrench.

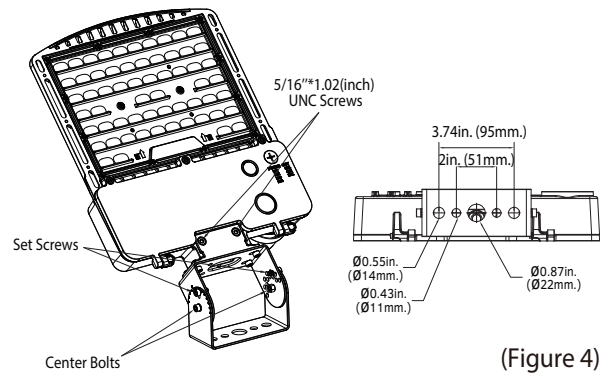

(Figure 4)

Adjustable Pole Mount (Figure 5)

1. Loosen the six PM4*12 screws and remove the two side plates.
2. Attach the bracket to the pole using the provided two 3/8" screws, placing the required gaskets between the pole and bracket. If installing on a round pole, use Gasket A only. If installing on a square pole, use both Gasket A and Gasket B.
3. Loosen the M10 screw and adjust the fixture to the desired angle.
3. Route the cord into the mounting bracket through the wiring hole, slide the fixture onto the bracket and tighten the two bottom 5/16" screws.
4. Make wiring connections as per the wiring diagram on the next page, replace the two side plates, and fasten the PM4*12(mm) screws. When replacing the side plates, make sure that the power cord is not exposed and does not press against the wiring.

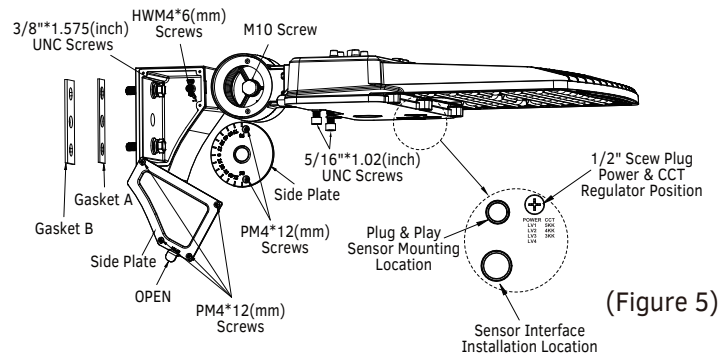

(Figure 5)

Power & CCT Adjustment Controls

1. Remove the 1/2" screw plug on the bottom of the fixture.
2. Using the Power (white) and CCT (black) dial switches, set the fixture to the desired power and CCT output. Refer to Figure 6 for options.
3. Replace the 1/2" screw plug and tighten with a flat head screwdriver.

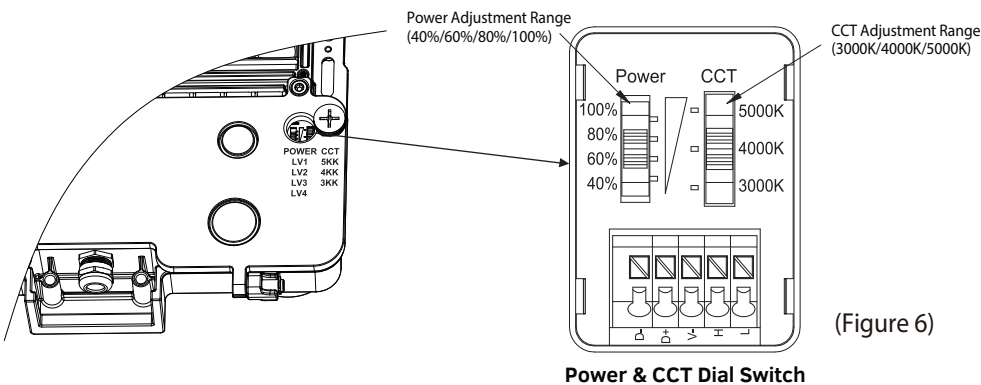

(Figure 6)

Power & CCT Dial Switch

Wiring Diagram

Note: Two dimming wires in the the driver box.

LED Fixture	Black	Line
	White	Neutral
	Green/Yellow Green	Ground
	Purple	DIM+
	Pink	DIM-

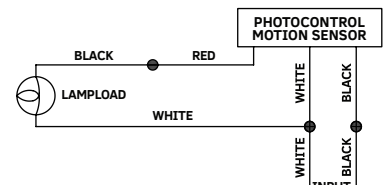

Note: Power & CCT Adjustment Controls on 400W

1. Though 3000K is indicated on the controls on the 400W model housing, 3000K is not available for 400W.
2. On all wattages except 400W, power adjustment controls may be set to 100%, 80%, 60%, or 40%, whereas on 400W, power adjustment controls are set to LV1 (400W), LV2 (360W), LV3 (320W), or LV4 (300W).

Mounting Accessories

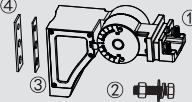
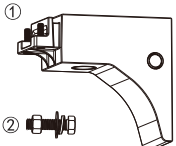
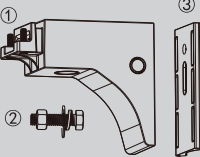
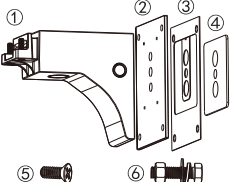
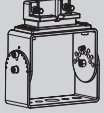
Mounting Type	Accessory	Specifications	Quantity
 Slipfitter Mount	Slipfitter Mount	Adjustable Slipfitter	1
 Adjustable Pole Mount	① Adjustable Pole Mount	235 x 90 x 152mm Adjustable Pole Mount	1
	② Bolt	#3/8"*1.575" Stainless Steel Hexagon Head Bolt	2
	③ Gasket A	L100W22H2 Gasket	1
	④ Gasket B	L100W30H3 Gasket	1
 Square Pole Mount	① Pole Mount Arm	202 x 177 x 90mm Square Pole Mount Arm	1
	② Bolt	#1/2" x 1.97" Stainless Steel Hexagon Head Bolt	2
 Round Pole Mount	① Pole Mount Arm	202 x 177 x 90mm Square Pole Mount Arm	1
	② Bolt	#1/2" x 1.97" Stainless Steel Hexagon Head Bolt	2
	③ Adaptor	177 x 88 x 13mm Round Pole Adaptor	1
 Wall Mount	① Pole Mount Arm	202 x 177 x 90mm Square Pole Mount Arm	1
	② Wall Mount Plate	203 x 152 x 5mm Steel Plate	1
	③ Wall Mount Template	203 x 152 x 1mm Plastic Template	1
	④ EVA Gasket	L119W119H30 40° EVA Gasket	1
	⑤ Bolt	KM4 x 10" Stainless Steel Flat Head Bolt	4
	⑥ Bolt	#1/2" x 1.46" Stainless Steel Hexagon Head Bolt	2
 Yoke Mount	Yoke Bracket	L129.5W60H88 Upper Bracket + L138W60H88 Lower Bracket +L44.5W115H49 Bracket	1
Other	Twist-Lock Photocell	120-277V 3-Pin	1
	Receptacle	3-Pin Receptacle	1
	Occupancy Sensor	120-277 0-10V Bi-Level	1