

! WARNING

PRIOR TO INSTALLATION, ENSURE THE MOISTURE LEVEL IN THE INSTALLATION ENVIRONMENT WILL NOT EXCEED THE LEVEL THAT THE MAGNETIC STRIP KIT IS RATED FOR.

- To prevent personal injury or product damage only licensed electricians should install.
- To avoid electric shock or component damage, disconnect power before attempting installation or servicing.
- This product must be installed in accordance with the national electric code (NEC) and all applicable federal, state, and local electric codes and safety standards.
- Disconnect product and allow cooling prior to servicing.
- THIS PRODUCT MUST BE INSTALLED IN ACCORDANCE WITH THE APPLICABLE INSTALLATION CODE BY A PERSON FAMILIAR WITH THE CONSTRUCTION AND OPERATION OF THE PRODUCT AND THE HAZARDS INVOLVED.
- Install this kit only in luminaires that have the construction features or dimensions specified in the drawings/instructions.
- To prevent wiring damage or abrasion, do not expose wiring to edges of sheet metal or other sharp objects.
- Do not make or alter any open holes in the enclosure of wiring or electrical components during kit installation.
- To avoid potential fire or shock hazard, do not use this magnetic strip kit in luminaires employing shunted bi-pin lampholders.
- Any alteration or modification of this product is expressly forbidden as it may cause serious personal injury, death, property damage, and/or product malfunction.
- Installers should examine all parts not intended to be replaced by the magnetic strip kit for damage and replace any damaged parts prior to installation of the kit.
- Risk of fire. Regardless of the configuration(s) of the magnetic strip kit, the input ratings of the overall kit should not exceed the marked input ratings of the host fixture.
- This luminaire is designed to operate in ambient temperatures ranging from -4°F to 104°F.
- Suitable for damp locations.
- WARNING: RISK OF FIRE OR ELECTRIC SHOCK.
- VAPOR BARRIER MUST BE SUITABLE FOR 194°F.

Installation Guide

IMPORTANT: Suitable for installation in troffer and wraparound lights with a minimum size of 42.58in x 9.84in x 1.18in.
 The minimum installed distance between the two light bars should be 1.97in.



1. Open the cover of the fixture where the magnetic strip kit will be installed.

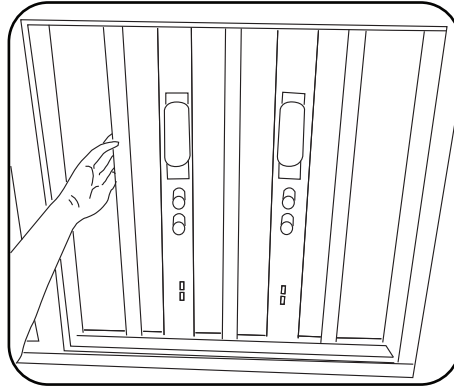

2. Remove the old fluorescent tubes and ballast.

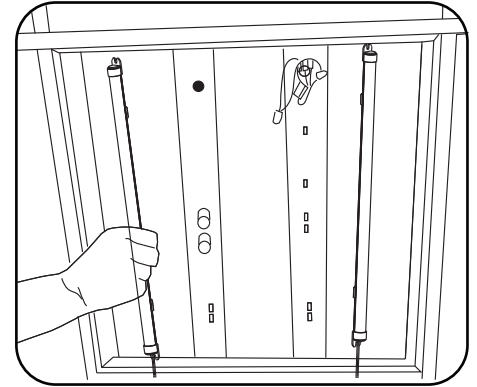

3. Install LED light bars using magnetic back, or, if not suitable, the included hexagon head self-tapping screws.

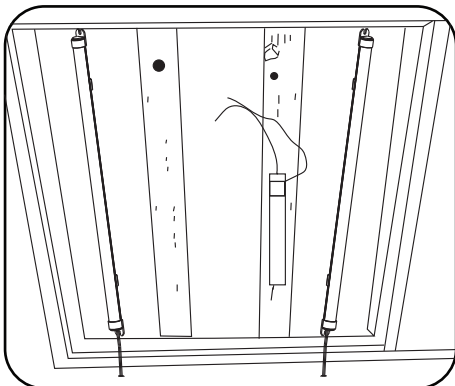

4. Install LED driver using magnetic back, or, if not suitable, the included hexagon head self-tapping screws.

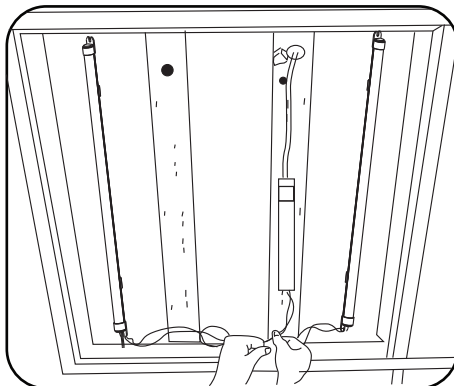

5. Connect the light bars to the driver using the connectors, then make wiring connections between driver and power source as per the wire diagram on the next page.

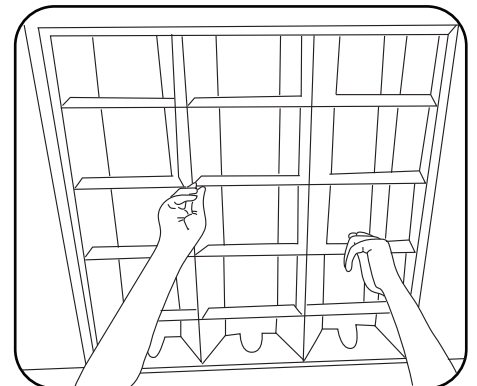

6. Replace the fixture cover to complete installation.

Power & CCT Adjustment Controls - Included

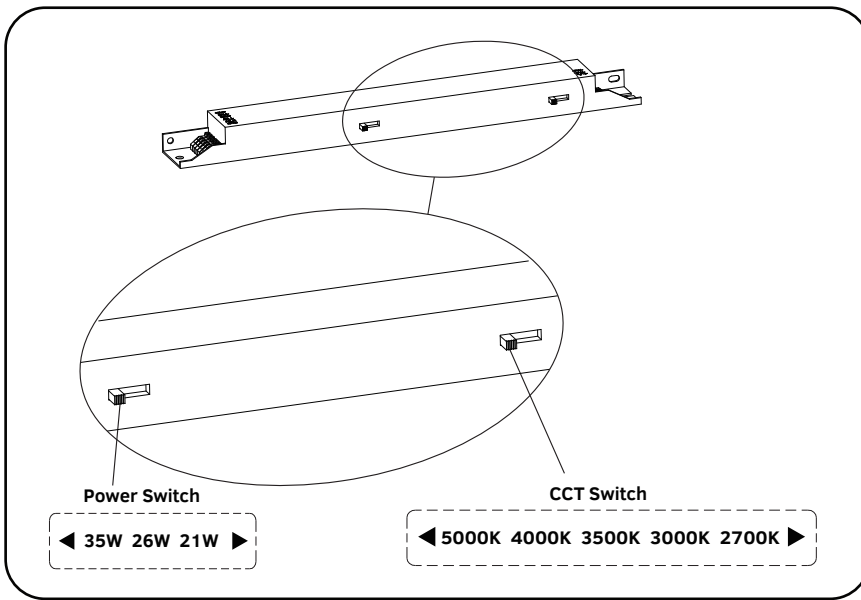

Power and CCT may be adjusted in the field using the two dip switches on the side of the driver. The power switch offers 3 power levels, and the CCT switch offers 5 CCT levels. Refer to the diagram to the left for available power and CCT settings.

Motion Sensor - Optional / Emergency Battery Backup - Special Order

If used, motion sensors and emergency battery backups should be installed in a suitable place in the middle of the fixture being retrofitted. Refer to the wiring diagram below for wiring instructions.

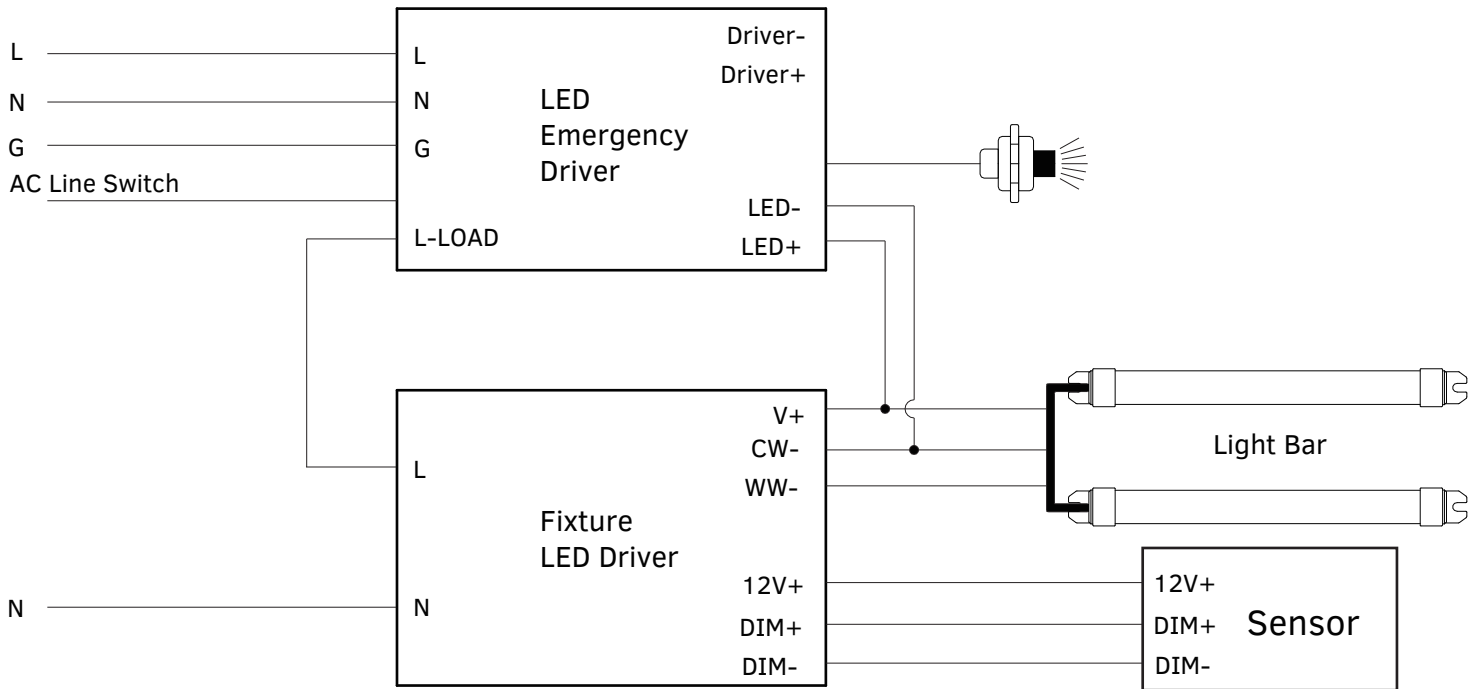

Wiring Diagram

For dimming version, refer to the wiring diagram below.

WITHOUT EMERGENCY BATTERY

LED FIXTURES	Black	Line
	White	Neutral
	Green	Ground
	Purple	DIM+
	Pink	DIM-
	Yellow	Sensor

WITH EMERGENCY BATTERY

LED FIXTURES	Red	AC line(24/7)
	Black	AC line switch
	White	Neutral
	Green	Ground
	Purple	DIM+
	Pink	DIM-
	Yellow	Sensor